

JOB NAME:

ITEM NO.:

QUANTITY:

PRODUCT NAME:

**WASTE VALVE CLAMP RING WRENCH**

\_\_\_\_\_ SPECIAL CONFIGURATION  
(CHECK BASE MODEL AND OPTIONS)

MODEL:

6130

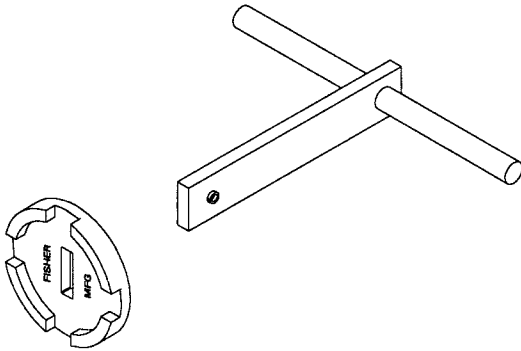

SHIPPING WEIGHT

\* 1.25 LBS

 ANSI/A112.18.1M