

APPLICATION:  
 JOB NAME:  
 QUANTITY:                      ITEM NO.

PRODUCT NAME:  
 PRE-RINSE, SWIVEL STYLE,  
 BACKSPLASH MOUNT  
 SPECIAL CONFIGURATION  
 CHECK BASE MODEL AND OPTIONS  
 MODEL:  
 2611                      ULTRA SPRAY VALVE NO WALL BRACKET  
 2611-WB                  ULTRA SPRAY VALVE W/ WALL BRACKET

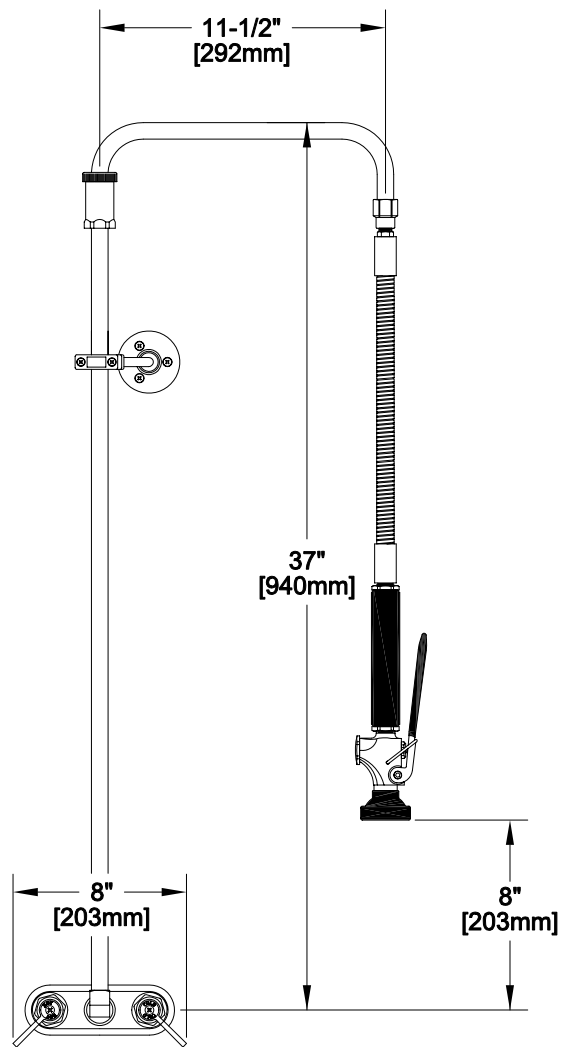

OPTIONS OR MODIFICATIONS:  
 SUPPLY LINES (24" OR 36") CIRCLE LENGTH  
 ADD-ON FAUCET (6", 8", 10", 12", 14", 16") CIRCLE  
 IN-LINE DUAL CHECK VALVE  
 PIPE HOOK  
 BRUSH  
 ELBOWS  
 HANDLES (CROSS OR WRIST) CIRCLE STYLE  
 VANDAL RESISTANT KIT  
 OTHER \_\_\_\_\_

FEATURES  
 CONTROL VALVE  
 \* 4" BACKSPLASH MOUNT  
 \* INTERNAL SPRING LOADED CHECK VALVES  
 \* HOT SIDE STEM - RIGHT HAND  
 \* COLD SIDE STEM - LEFT HAND  
 \* SWIVELLING SEAT DISKS  
 \* STAINLESS STEEL SEATS  
 \* STAINLESS STEEL SEAT SCREWS  
 \* STAINLESS STEEL HANDLE SCREWS

HOSE  
 \* 15-1/2" LENGTH  
 \* STAINLESS STEEL END FITTINGS  
 \* STAINLESS STEEL EXTERNAL JACKET  
 \* 3-PLY FIBER REINFORCED INTERNAL RUBBER HOSE

ULTRA SPRAY VALVE  
 \* LOWEST ENERGY USER - 1.15 GPM @ 60 PSI  
 \* CLEANS FASTER - TEST PROVEN  
 \* ENGINEERED TO LAST - NO 'O' RINGS TO LEAK  
 \* INTERCHANGEABLE - FITS ALL BRANDS

SYSTEM LIMITS  
 \* TEMP: 40°F MIN. TO 140°F MAX.  
 \* PRESSURE: 200 PSI MAX. STATIC

SHIPPING WEIGHT  
 \* 12.0 LBS

**ROUGH-IN:**

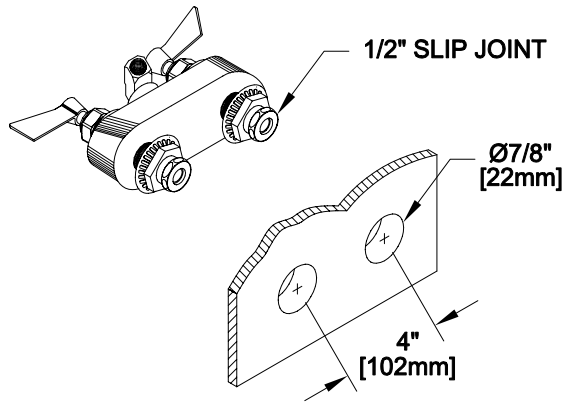

FISHER MANUFACTURING COMPANY  
 TOLL FREE: 800-421-6162 - FAX: 800-832-8238  
 information@fisher-mfg.com - www.fisher-mfg.com