

Why Fisher?...

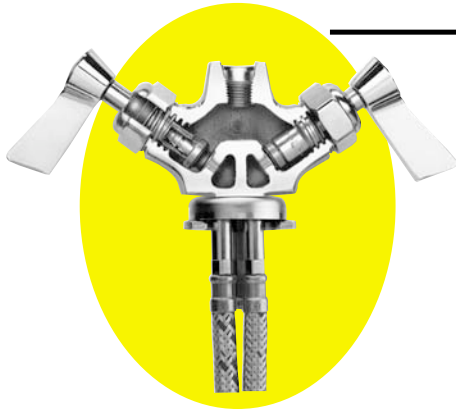

FAUCETS

- *Stainless Steel Seats Guaranteed for Life.*
- *Two Part Swivel Stems for Lower Maintenance.*

PRE-RINSE SPRAY VALVES

- *Lowest Energy User - 1.15 GPM @ 60 PSI*
- *Cleans Faster - Test Proven*
- *Engineered to Last - No "O" Rings to Leak*
- *Interchangeable - Fits ALL Brands*

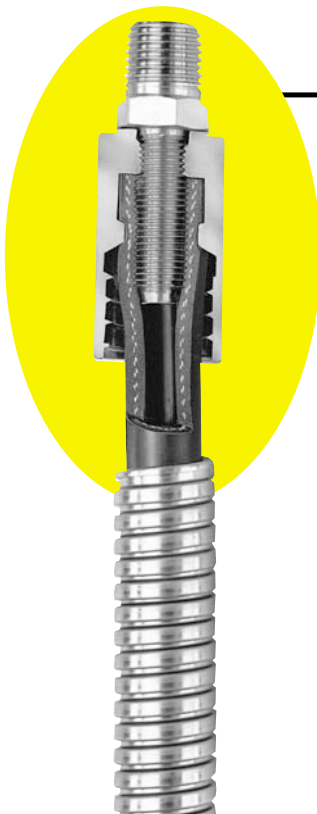

PRE-RINSE HOSES

- *Three Ply "Aircraft" Hydraulic Hose.*
- *Lasts three times longer*
- *Fits ALL Brands*

DRAINING™

- *Stainless Steel Only Where it Counts, Means Value.*
- *Two TEFLON® Seals - instead of one - Means NO Leaks.*
- *Guaranteed for Three Years.*

